

X-Yachts France

, Rue des Voiliers - 83360 PORT-GRIMAUD

Tél. 94 56 28 54 - Fax 94 56 30 16

SARL au Capital de 50.000 F.

RCS SAINT-TROPEZ B 381 410 430 00016

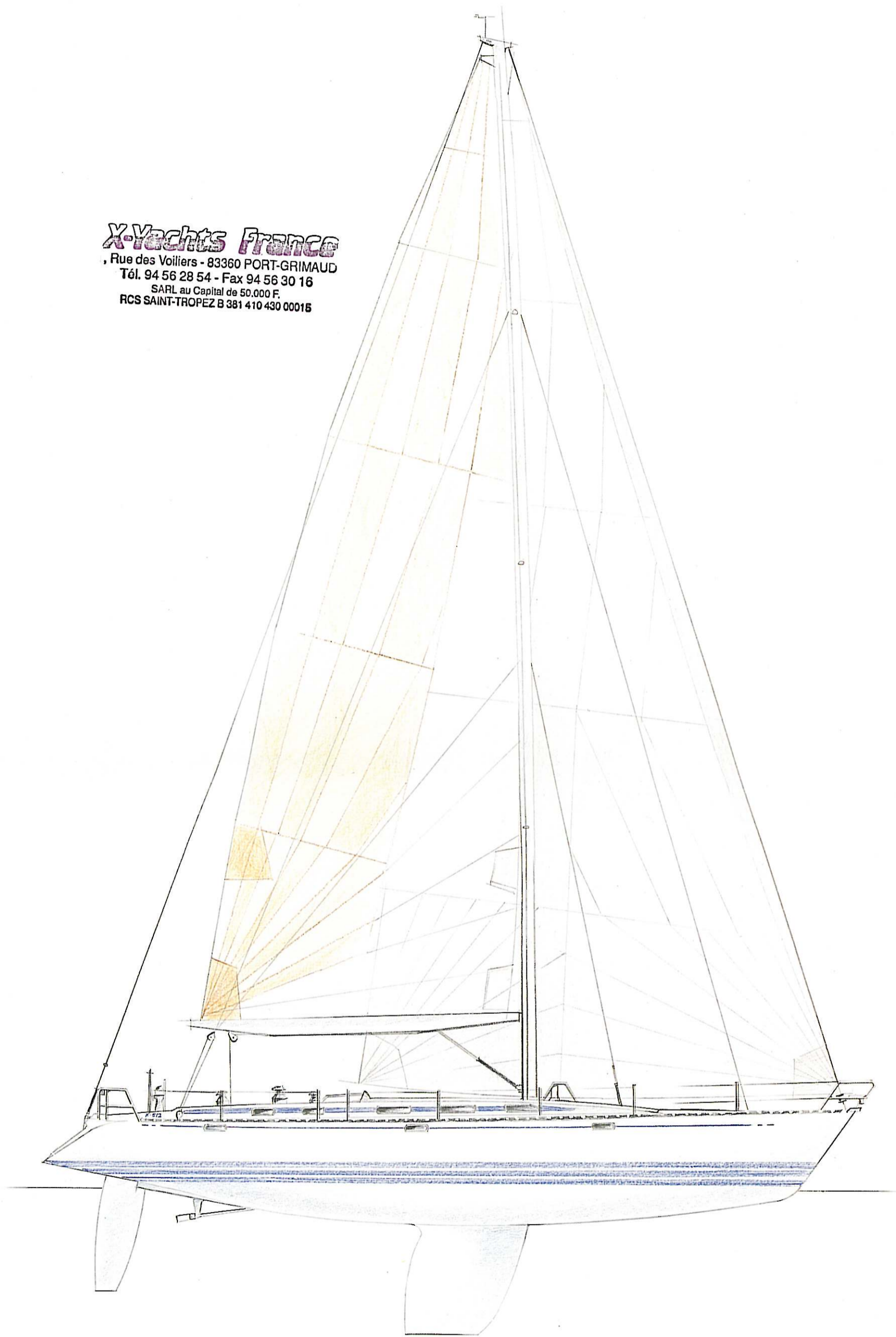

X-Yachts

*X-512 Cruiser/Racer. Designed by Niels Jeppesen.
From X-Yachts of Denmark*

X-512

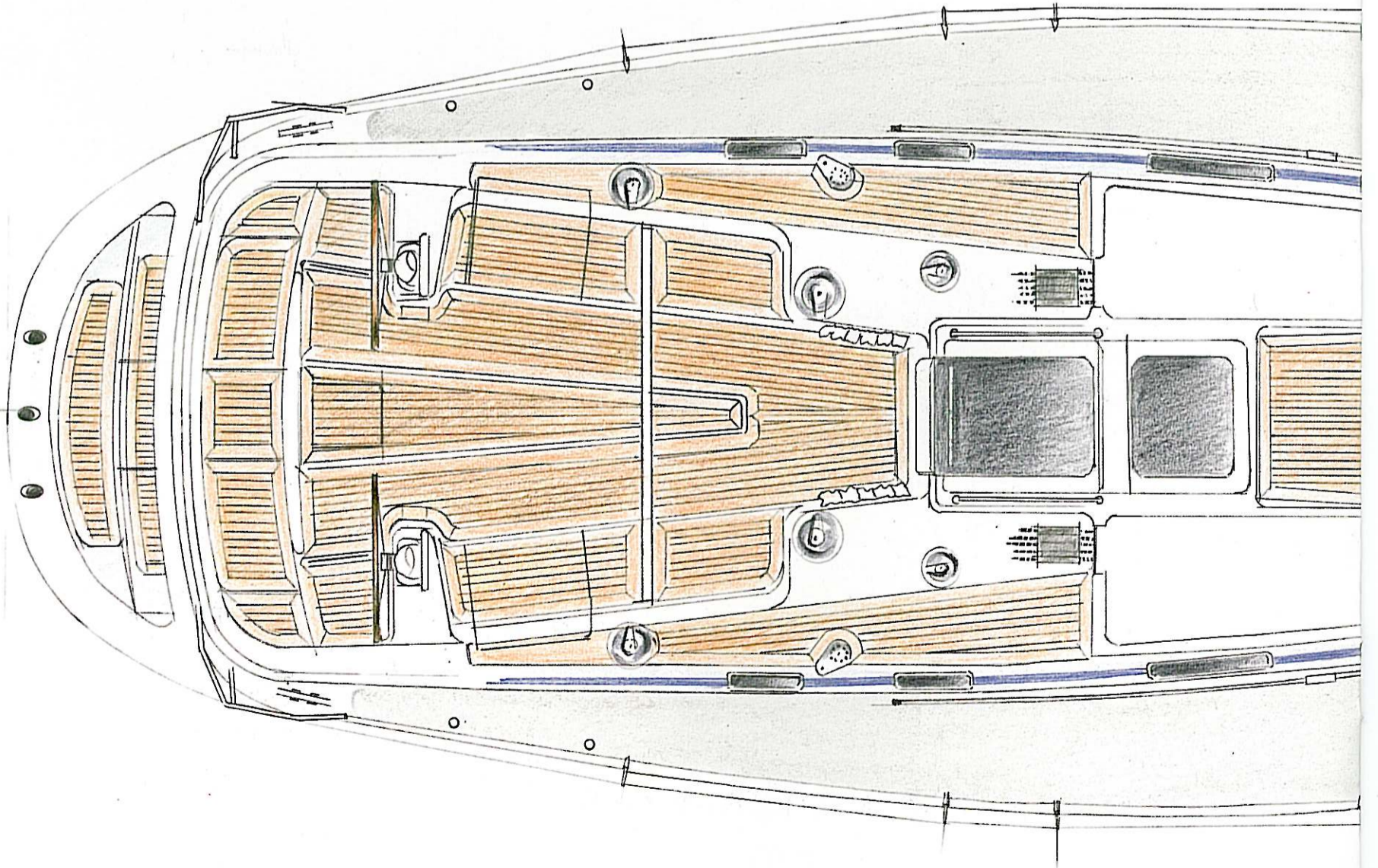

Introduction

The X-512 has her niche in today's demanding market. The ideas behind the development of her hull, deck, keel,

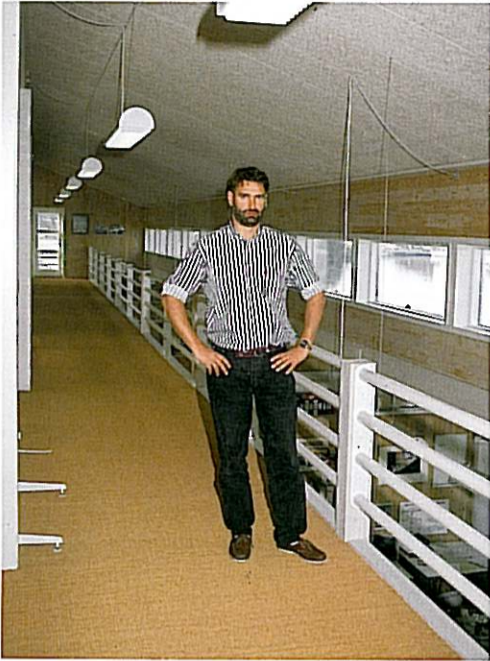

interior and rig have been weighed and analyzed for more than three years. Finally the launching of this superyacht is a reality. The X-512 is designed and built to be an ultimate high performance offshore yacht - optimized to meet the demands of the discerning owner.

Philosophy

One quality in particular will characterize the X-512 ... She must have outstanding sailing characteristics compared to other yachts of her size. The

fundamental philosophy of the X-Yacht yard is not to cater to the whims of outside designers and stylists, but to do all the development work in-house, based on the idea that high quality racers and cruisers must build on the importance of weight distribution.

Construction - Deck Hardware

Both hull and deck are built of the most modern materials ... not necessarily the most economical productionwise - hand layed up laminates, the use of isotactic polyester, biax and triaxial layers, both hull and deck, sandwich constructions. All heavy items such as engine, generator, batteries, and tanks are all grouped as closely as possible to the yacht's centre. The keel is of specially hardened lead, the rudder stock couched in double roller bearings for optimal "feel", the rudder post is a special double tapered aluminium, allowing perfect blade profile.



Propeller to be either folding or feathering, deck hardware to be of first class quality, dimensioned for easy and comfortable sailing.

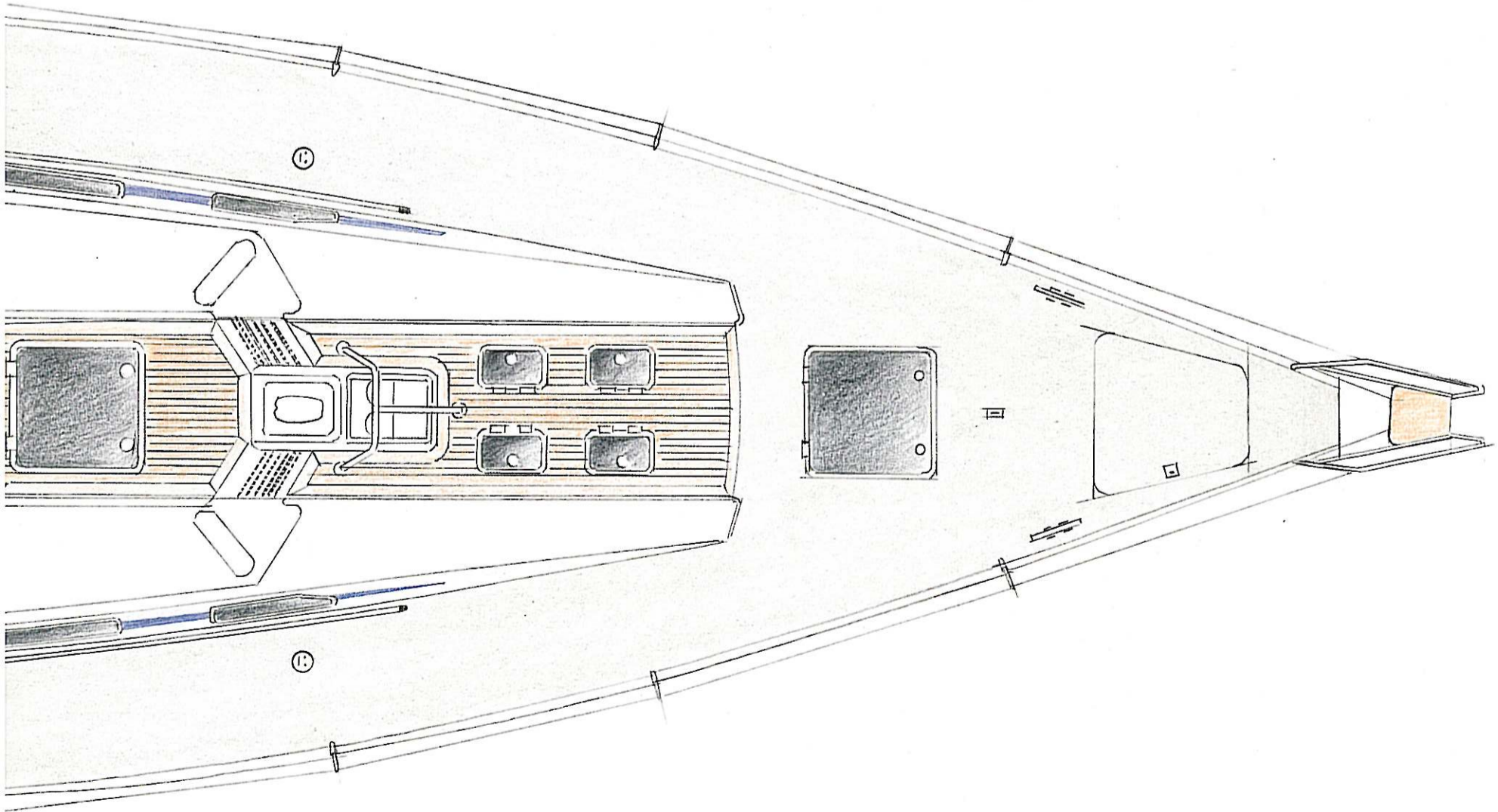

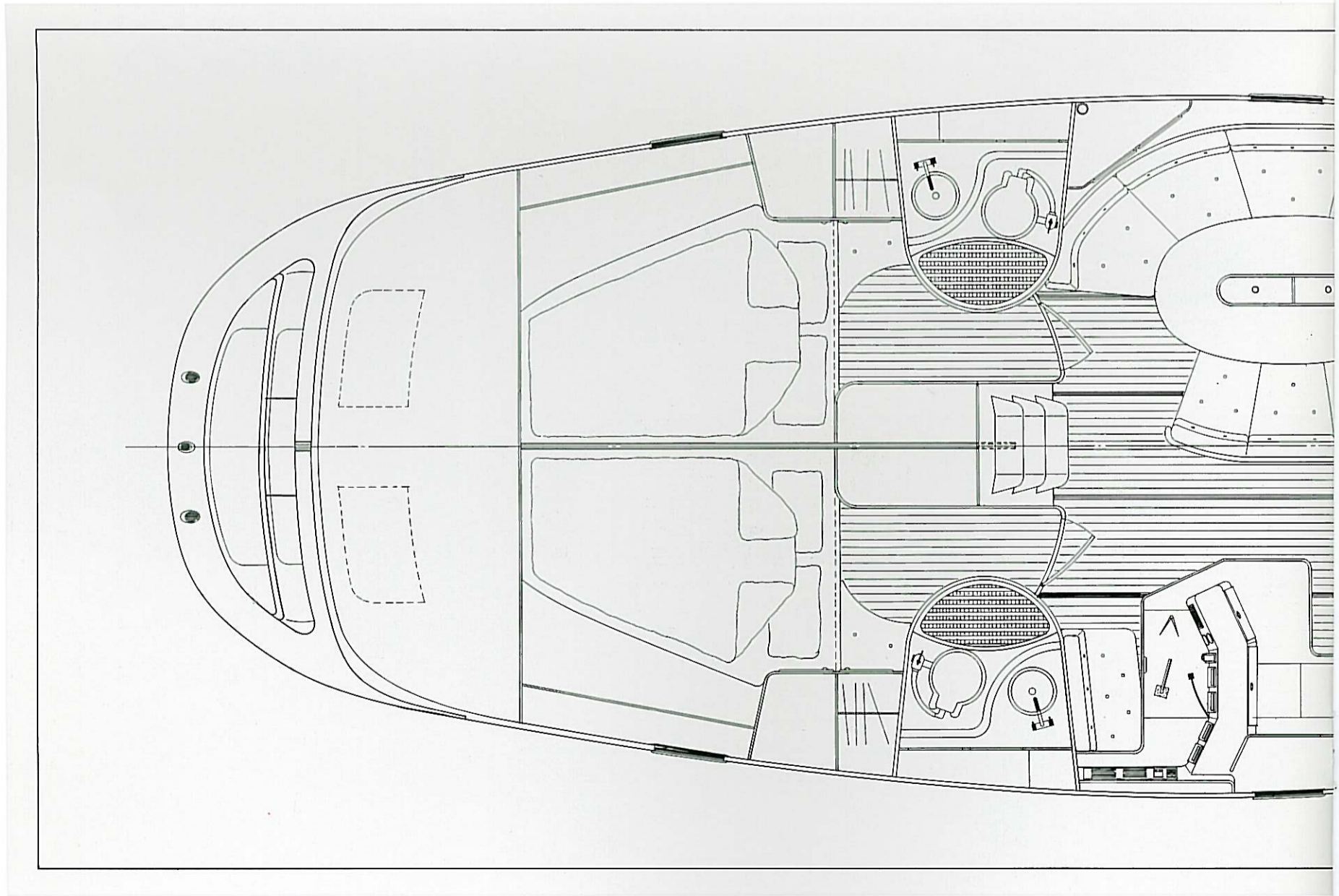

Accommodations in general

Numerous skylights, sliding hatches, port-holes and vents ensure optimal ventilation throughout the high class interior. Bulkheads in both ends built of composite materials. (The forward bulkhead is watertight - the yacht can be provided with an ABS Classification Certificate.) Laminated bulkheads and other detailing dominate the stylish interior.

Aft Cabins

As standard, 2 symmetrical aft cabins are provided - both having the option of hanging one or two removable, adjustable frame bunks. Each cabin has its own head/shower.

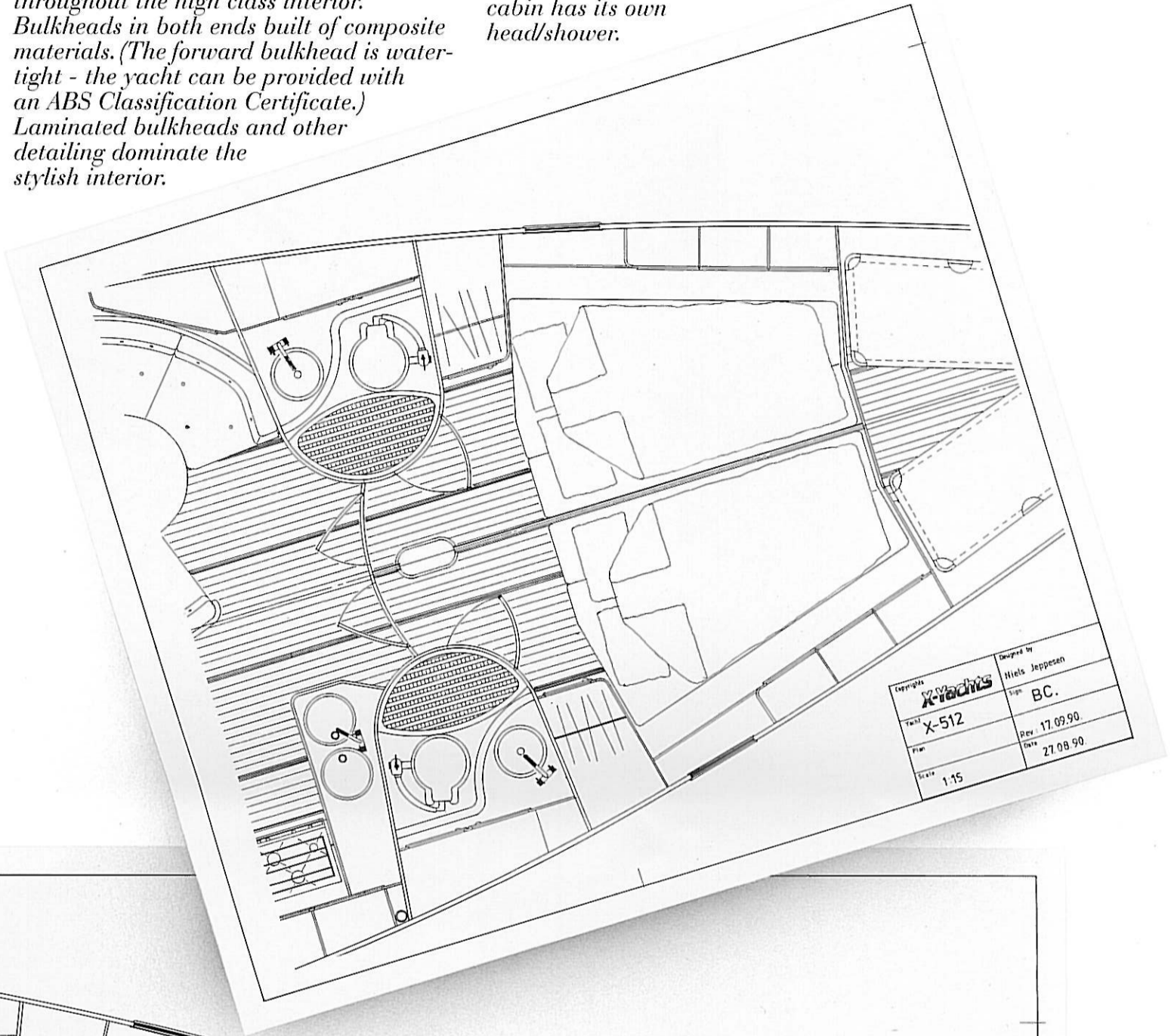

Copyright	X-Yachts	Designed by	Niels Jeppesen
Yacht	X-512	Sign	BC.
Plan		Rev	17.09.90.
Scale	1:15	Date	27.08.90.

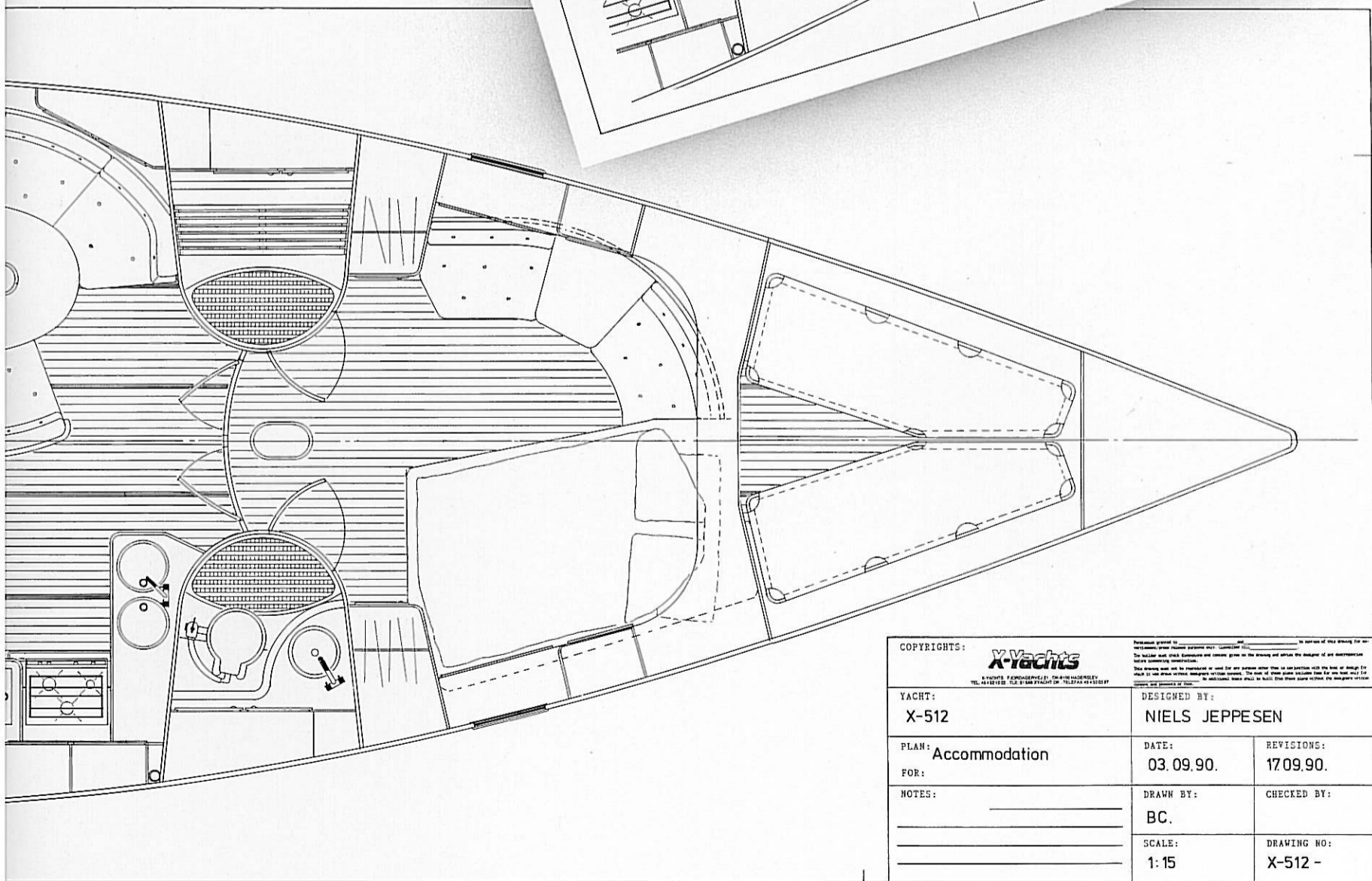

<small>COPYRIGHTS:</small>  <small>REGISTERED TRADEMARK OF X-YACHTS A/S, DENMARK</small>		
<small>YACHT:</small> X-512	<small>DESIGNED BY:</small> NIELS JEPPESEN	
<small>PLAN:</small> Accommodation <small>FOR:</small>	<small>DATE:</small> 03.09.90.	<small>REVISIONS:</small> 17.09.90.
<small>NOTES:</small> _____ _____ _____	<small>DRAWN BY:</small> BC.	<small>CHECKED BY:</small> _____
	<small>SCALE:</small> 1:15	<small>DRAWING NO.:</small> X-512 -

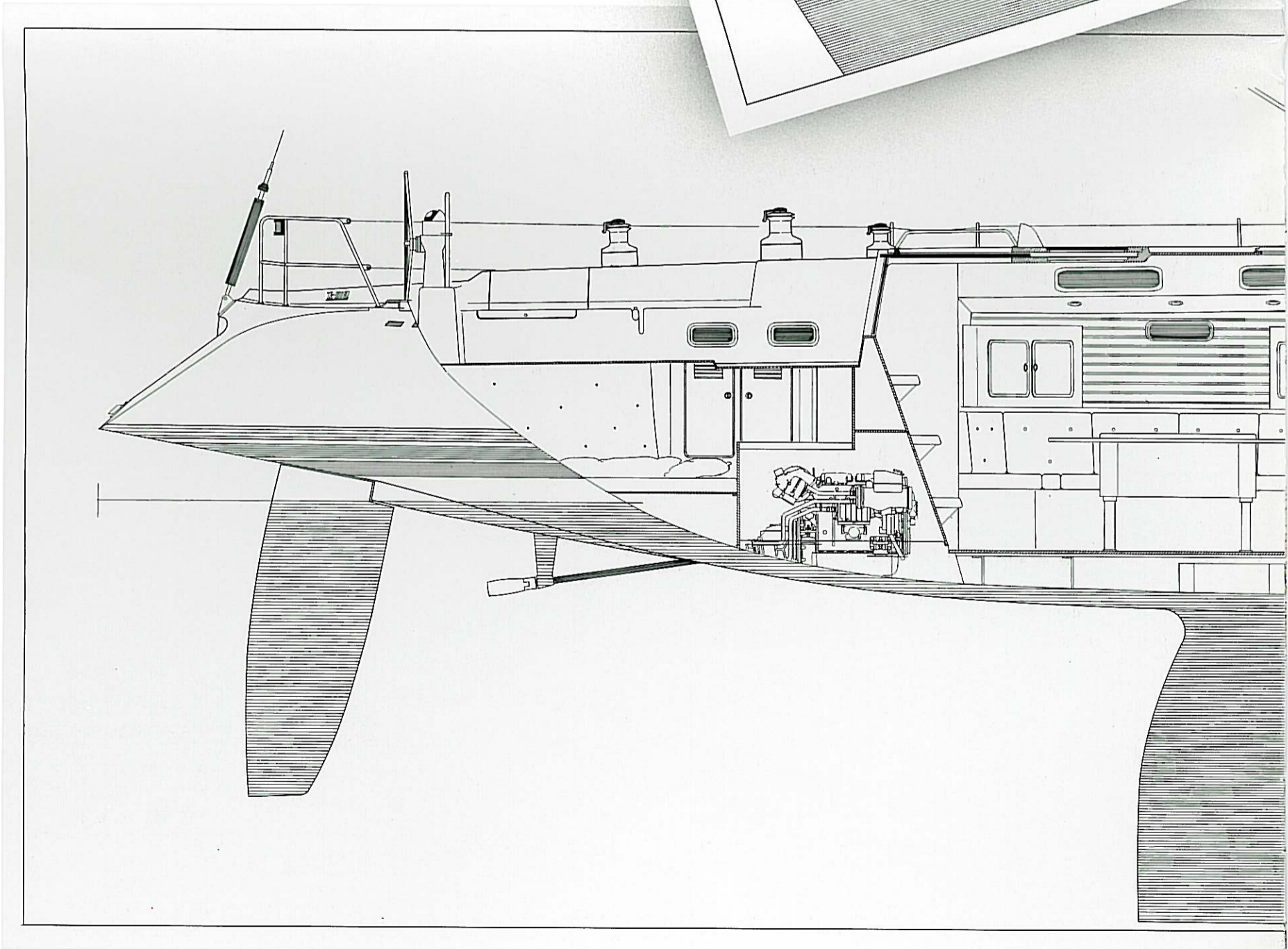
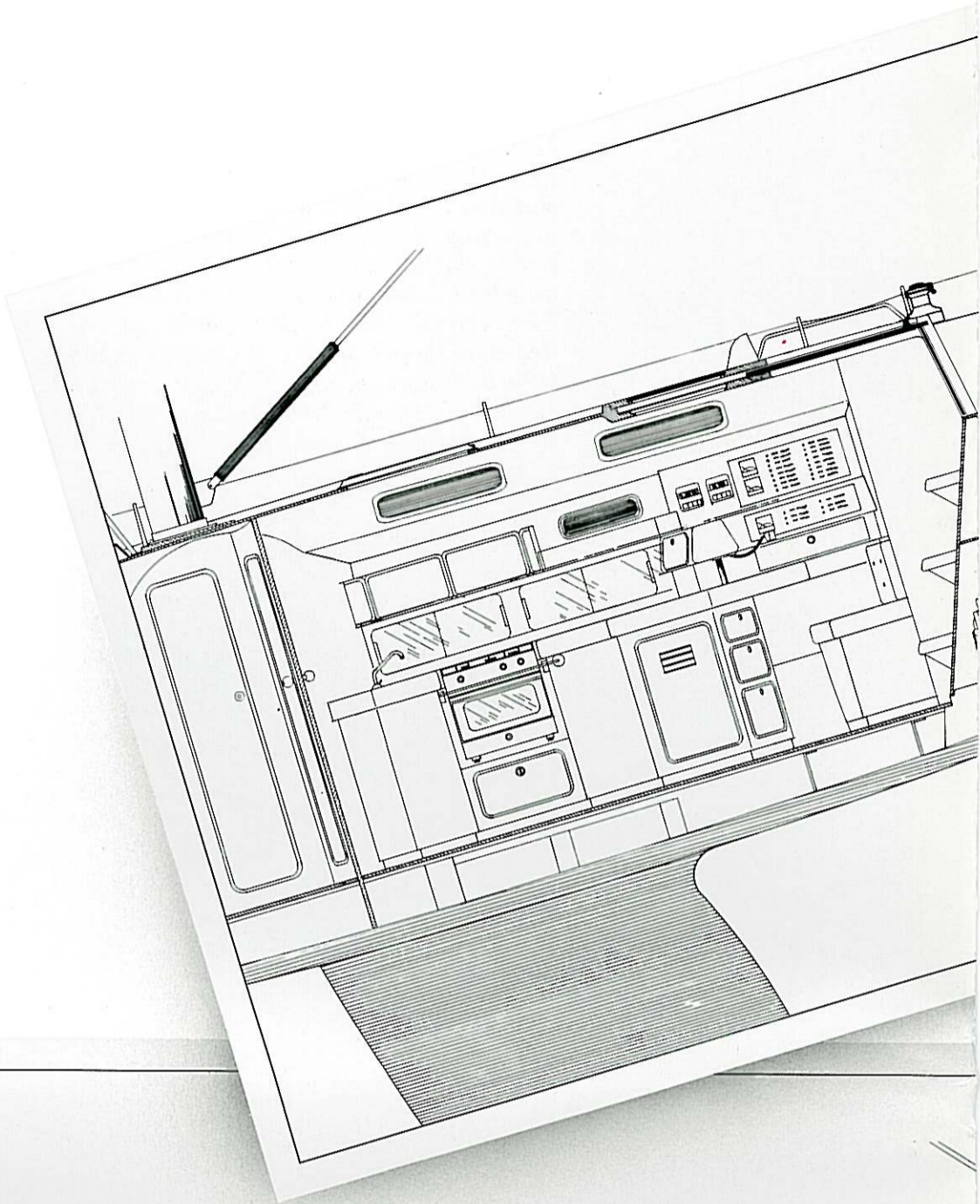
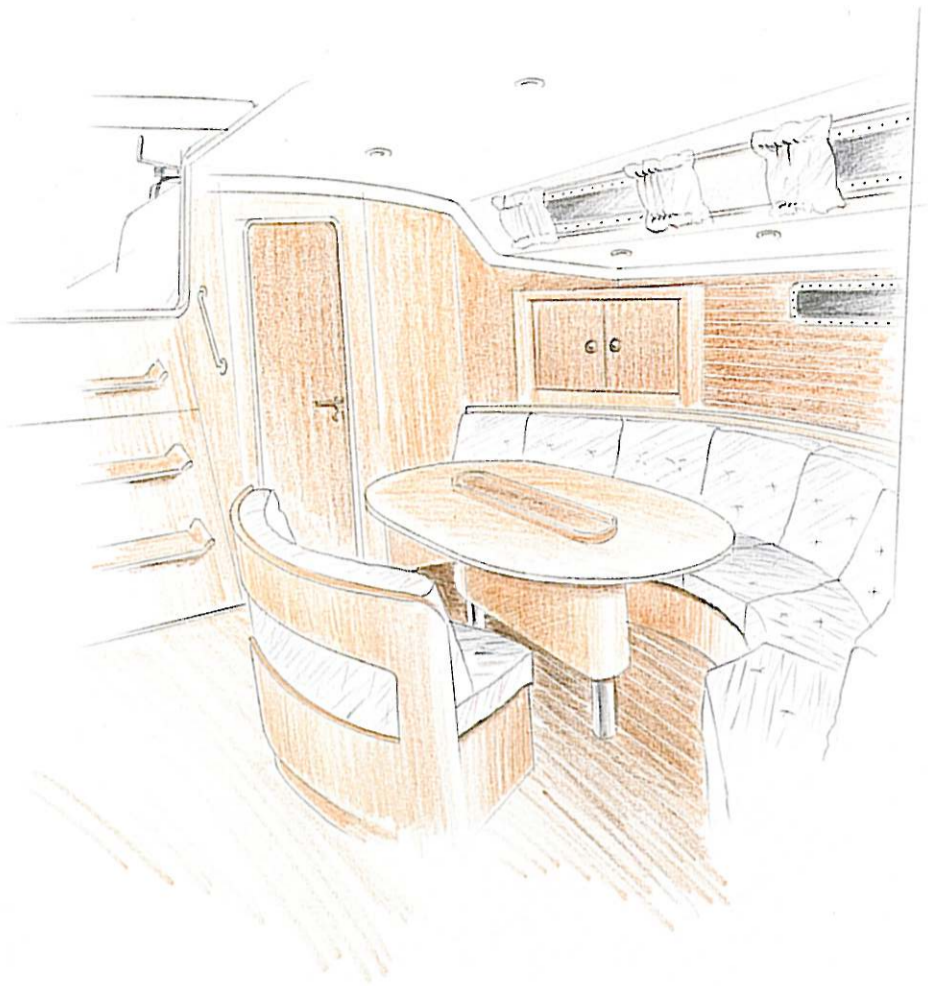

Main Cabin/- Navigation/Galley

The large main cabin enables nine guests to dine comfortably around the oval table. The comfortable, classic navigation area has space for every modern navigational installation, switchboard for the yacht's electrical installations, as well as shore-power. The modern galley includes gas oven, double burner stove, ample electrical refrigerator, large selfdraining cooler-box, hot and cold pressurized water, and plenty of space for both provisions and galley equipment.

Owners Cabin

The owners cabin, forward of the main bulkhead, has its own head, shower, double berth, two comfortable armchairs, with central night table, desk/computer table, and bar. Forward of the watertight bulkhead, there is plenty of space for

sails, inflatable dinghy, bicycles etc. optional installation of two adjustable, removable frame bunks, sink and toilet for professional crew. A four-cabin alternative is also available. The longitudinal bulkheads between cabins are sound-isolated.

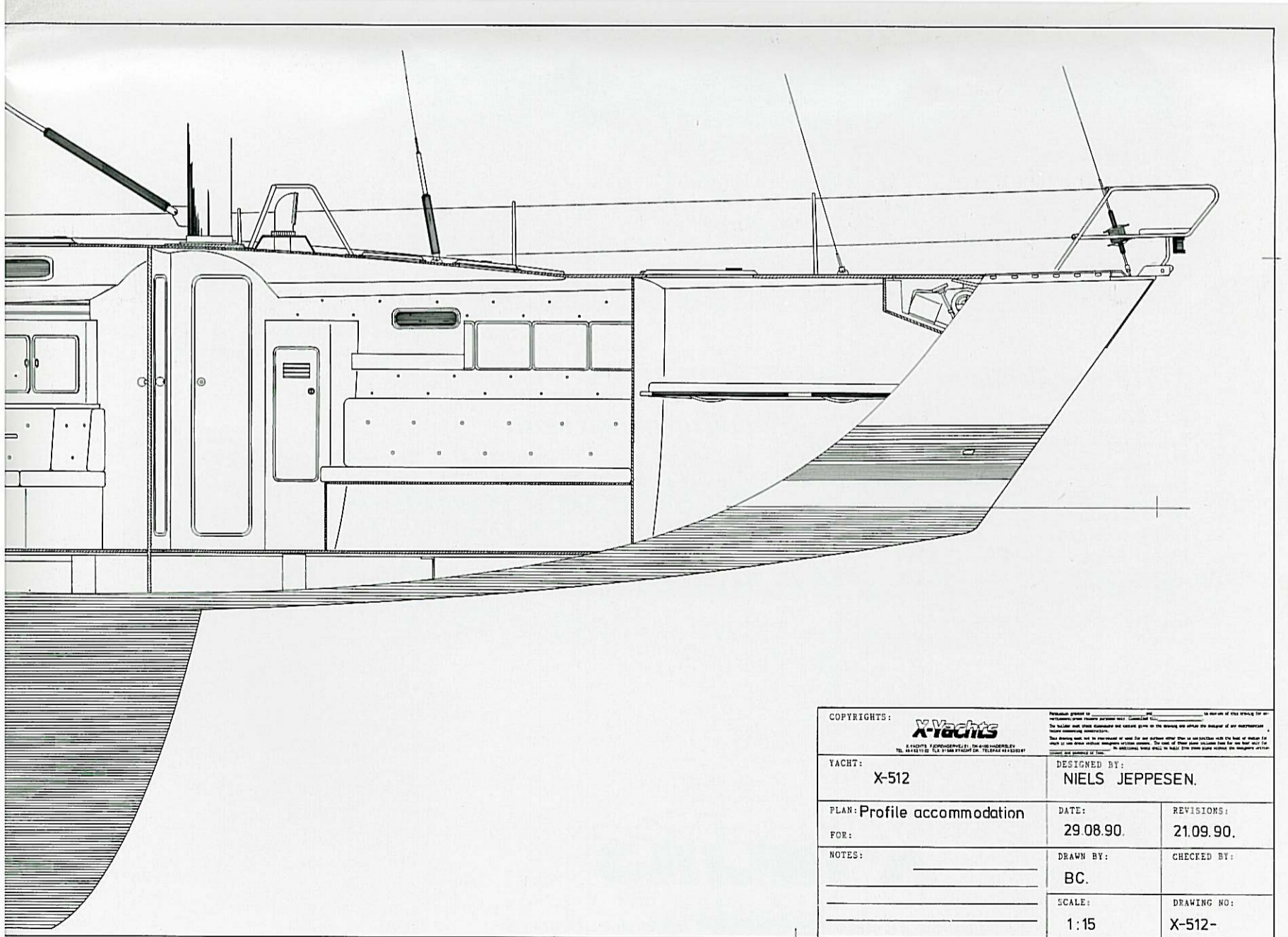
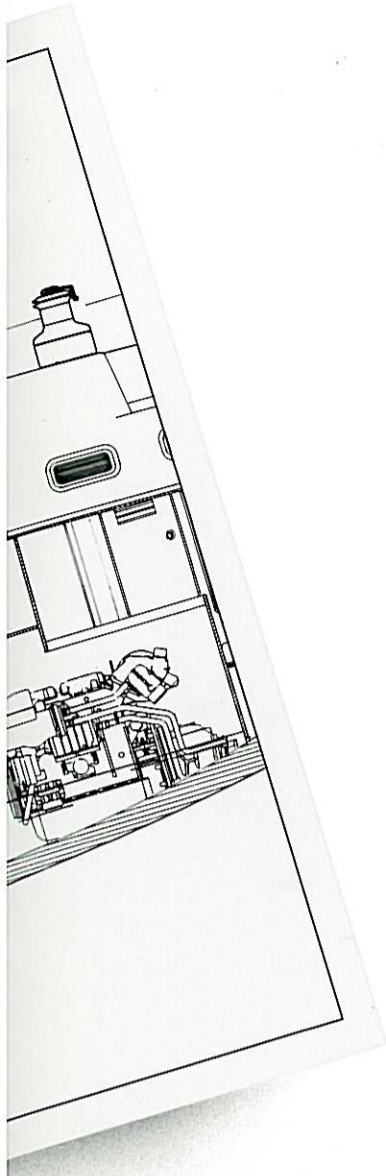
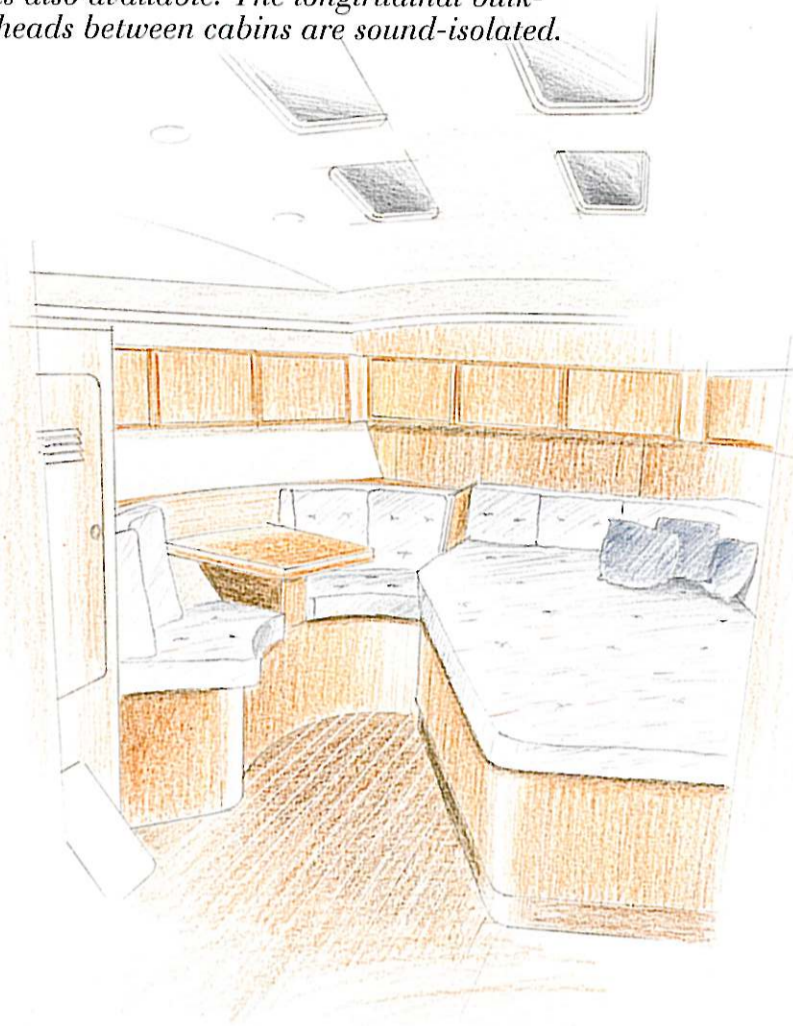

<small>COPYRIGHTS:</small>  <small>DESIGNED BY: NIELS JEPPESEN</small> <small>ALL RIGHTS RESERVED. FOR SALE AND EXPORT ONLY. THE YACHTS ARE NOT TO BE REPRODUCED OR USED FOR ANY PURPOSE OTHER THAN TO IDENTIFY THE YACHTS OF THIS TYPE. THE YACHTS ARE NOT TO BE REPRODUCED OR USED FOR ANY PURPOSE OTHER THAN TO IDENTIFY THE YACHTS OF THIS TYPE. THE YACHTS ARE NOT TO BE REPRODUCED OR USED FOR ANY PURPOSE OTHER THAN TO IDENTIFY THE YACHTS OF THIS TYPE.</small>		
YACHT:	X-512	
DESIGNED BY:	NIELS JEPPESEN.	
PLAN:	Profile accommodation	
DATE:	29.08.90.	REVISIONS:
		21.09.90.
FOR:		
NOTES:		
DRAWN BY:	BC.	CHECKED BY:
SCALE:	1:15	DRAWING NO:
		X-512-

	Standard	Option
HULL white with blue moulded stripes	Hull and closed transom laminated in one piece. Biax and triaxial fabrics isotalic polyester. Divinycell foam core.	Transom with bathing platform. 6 hull windows. Coloured hull on request.
DECK white with blue cabinsides. Light grey anti-slip areas at sidedecks and in cockpit.	Biax - and triaxial fabrics - isotalic polyester. Divinycell foam core.	Teak at sidedecks and cockpit.
KEEL combined lead (bottom) and cast iron (top).		Shallow draft wing. Torpedo keel draft 2.00 m (9.1 ft).
MAST/RIG standing throug deck.	3 spreader/tapered discontinued rod rig. 5 halyards. Navtec hydraulic backstay. Tapered boom. Spinn pole.	Furling mast with 2 spreaders - continued wire rigging. Furling headstay.
ENGINE 4 cyl Volvo. Folding prop.		100 HP. Feathering 3 blade.
FUEL stainless ss	320 ltrs.	Extra 130 ltrs.
WATER stainless ss	570 ltrs.	Extra 230 ltrs.
HOT WATER - stainless	20 ltrs.	Extra 20 ltrs.
WINCHES	2 x lewmar 66 ast. 2 x lewmar 56 ast. 2 x lewmar 52 ast.	Coffee grinder system. Electrical winches. Anchorwinch 1500 w.
BLOCKS/TRACKS	Lewmar/Frederiksen racing	
REFRIGERATOR	140 ltrs. frontopened. 150 ltrs. cooling box.	Freezing compressor to extra 90 ltrs.
ELECTRICAL SYSTEM	7 x 70 amp/h batteries. Yachts custom switch board. Shorepower with switch board.	3 x 70 amp/h batteries.
BATTERY CHARGING	1 x 50 amp/h engine alterna. 1 x 25 amp/h shorponeres batt. charger.	
OTHERS	Launching in Denmark.	

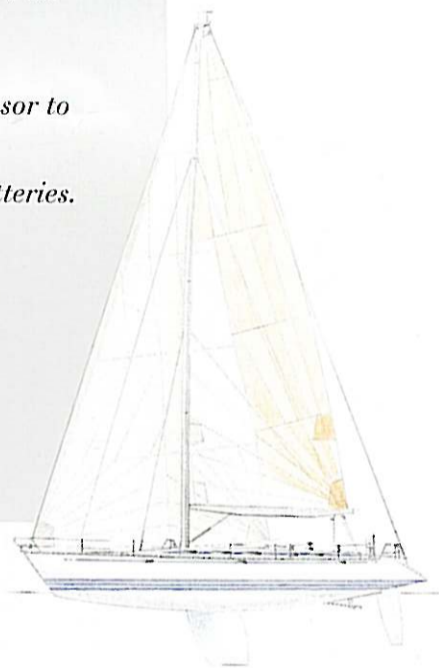

X-512 Specifications:

L.O.A.	15.590 m	51.1 ft
L.W.L.....	12.660 m	41.5 ft
B. max.....	4.500 m	14.8 ft
Draft.....	2.000/2.800 m	9.1/9.8 ft
Ballast.....	6.000 kg	13.229 LB
Displacement.....	13.658 kg	30.112 LB
Cabin height.....	1.95 m	6.4 ft
Engine diesel.....	46 kW	62 HP

Sail areas and mast:

Main sail	65.24 m ²	702.2 ft ²
Genoa I 150%.....	92.48 m ²	995.0 ft ²
Genoa II 130% ...	80.15 m ²	862.4 ft ²
Genoa III 100% ..	61.65 m ²	663.3 ft ²
Spinnaker	204.40 m ²	2.200 ft ²
Length mast.....	22.160 m	72.6 ft



Fjordagervej 21 · Box 104 · DK-6100 Haderslev · Denmark
Tel. +45 74 52 10 22 · Tlx. 51588 xyacht dk · Fax +45 74 53 03 97

Represented in:
Austria · Brazil · Canada · Finland · France · Germany · Greece · Holland · Hongkong · Ireland · Italy · Japan · Malta
Norway · Portugal · Spain · Sweden · Switzerland · Turkey · U.K. · USA